

**DK-400 Bilgilendirme / Information**

- Çalışma Kuvveti / Working Force : (300.000 Baskı/Stroke)205,8 kN(21,0tonf)
- Sürücü Geniřliđi / Slider Width : 400 mm
- Çalışma Açısı / Work Angle : 0°
- 02 : CK45, 01 : GGG60 (Opsiyon) / 02 : CK45, 01 : GGG60 (Option)
- Sürtünme Plakası Opsiyonu / Wear Plate Option : P
- Gazlı Yay Opsiyonu / Gas Spring Option : GY
- Pim Deliđi Ø16H7 (Opsiyon) / Dowel Pin Ø16H7 (Option)
- Isıl İşlem Opsiyonu / Induction Option : I

**Kam Diyagram / Cam Diagram**

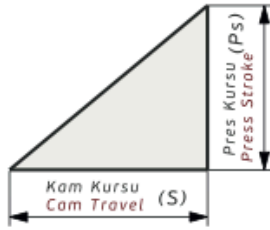

**Sipariř Örneđi / Order Example**

Kam Kodu Cam Code	Sürücü Geniřliđi Slider Width (mm)	Kurs Travel (mm)	Malzeme Material	Opsiyon Kodu / Option Code
(G)	(S)	01 / 02	<b>P-GY-F16-I Opsiyonları</b> <b>P-GY-F16-I Options</b>	
DK	- 400	- 60	- 01	- P - GY - F16 - I

**DK-400 Teknik Bilgiler / Technical Informations**

Çalışma Yüzeyi/Mounting Surface		Çalışma Açısı Work Angle (°)	Kam Kuru/Cam Travel Stroke (mm)	Çalışma Kuvveti Working Force	Yay Kuvveti Spring Force	Gazlı Yay Kuvveti Gas Spring Force (Opsiyon/Option)
(G)	(Gh)	(A)	(S)			
400	150	00	60	300.000 Baskı/Stroke 205,8 kN (21,0 tonf)  1.000.000 Baskı/Stroke 137,2 kN (14,0tonf)	9400 N (954 kgf)	23600 N (2400 kgf)

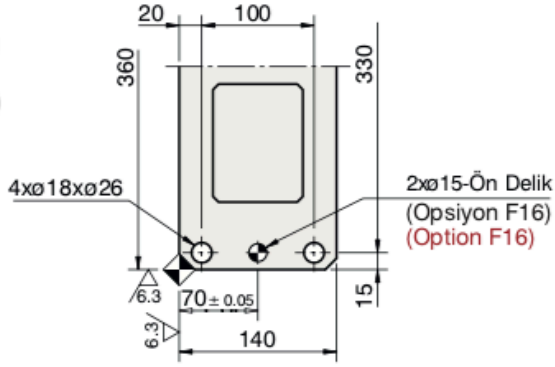

■ Kam Diyagramı / Cam Diagram

