

AKSOUK-200 Bilgilendirme / Information

- Çalışma Kuvveti / Working Force : (300.000 Baskı/Stroke) 196 kN (20,0tonf)
- Sürücü Geniřliđi / Slider Width : 200 mm
- Çalışma Açısı / Work Angle : 0° ~ 70°
- Gazlı Yay Opsiyonu / Gas Spring Option : GY
- Pim Deliđi Ø 12H7-13H7-16H7 (Ops.) / Dowel Pin Ø 12H7-13H7-16H7 (Opt)
- Sipariř Örneđi / Order Example : AKSOUK-200-15-P-GY-F13

Kam Diyagramı / Cam Diagram

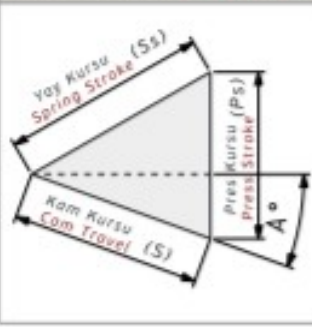

Sipariř Örneđi / Order Example

Kam Kodu Cam Code	Sürücü Geniřliđi Slider Width (mm)	Çalışma Açısı Work Angle (°)	Opsiyon Kodu / Option Code			
	(G)	(A)	Gazlı Yay Gas Spring	Pim Deliđi Dowel Pin	---	---
AKSOUK - 200 - 00						
AKSOUK - 200 - 25 - GY						
AKSOUK - 200 - 40 - GY - F16						

AKSOUK-200 Teknik Bilgiler / Technical Informations

Çalışma Yüzeyi/Mounting Surface		Çalışma Açısı Work Angle (°)	Kam Kuruřu/Cam Travel Stroke (mm)	Çalışma Kuvveti Working Force	Yay Kuvveti Spring Force	Gazlı Yay Kuvveti Gas Spring Force (Opsiyon/Option)
(G)	(Gh)	(A)	(S)			
200	100	00	28,3	300.000 Baskı/Stroke 196,0 kN (20,0 tonf)	5915 N (603 kgf)	11074 N (1130 kgf)
200	130	05	28,4		6456 N (659 kgf)	11074 N (1130 kgf)
200	100	10	33,3		6456 N (659 kgf)	11074 N (1130 kgf)
200	130	15	33,9		6456 N (659 kgf)	11074 N (1130 kgf)
200	100	20	30,9		6254 N (638 kgf)	11074 N (1130 kgf)
200	130	25	32,0		6254 N (638 kgf)	11074 N (1130 kgf)
200	120	30	33,5		5886 N (600 kgf)	11074 N (1130 kgf)
200	140	35	35,4	1.000.000 Baskı/Stroke 98,0 kN (10,0 tonf)	5886 N (600 kgf)	11074 N (1130 kgf)
200	120	40	39,0		5886 N (600 kgf)	11074 N (1130 kgf)
200	140	45	42,3		5886 N (600 kgf)	11074 N (1130 kgf)
200	140	50	46,7		5886 N (600 kgf)	11074 N (1130 kgf)
200	140	55	52,3		5886 N (600 kgf)	11074 N (1130 kgf)
200	140	60	60,0		5886 N (600 kgf)	11074 N (1130 kgf)
200	140	65	47,3		5754 N (587 kgf)	11074 N (1130 kgf)
200	140	70	58,5	5754 N (587 kgf)	11074 N (1130 kgf)	

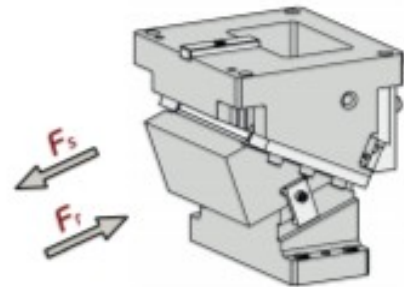
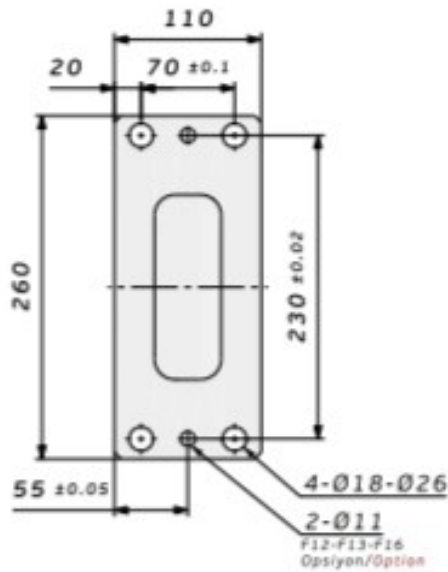
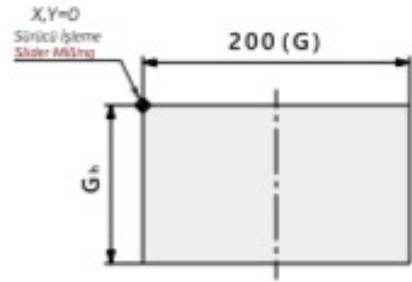
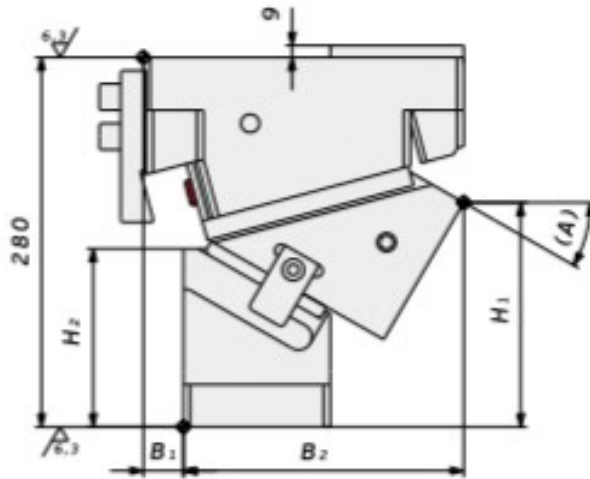
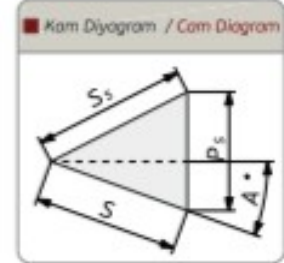
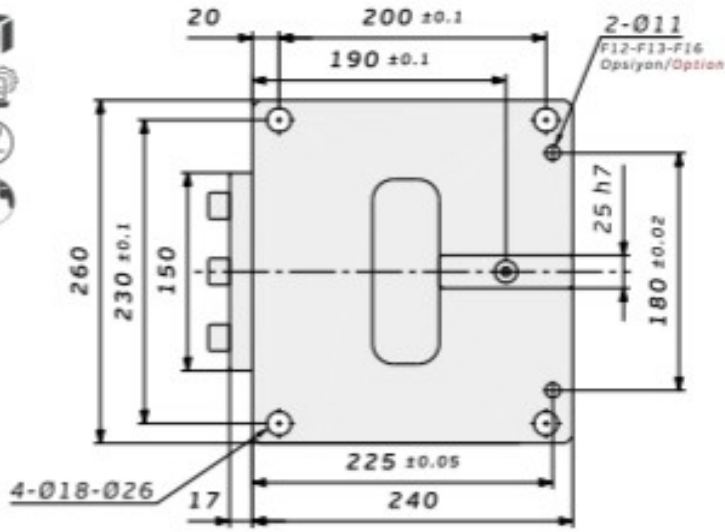

Kam Kodu Cam Kode	Açı Angle (A)	Ölçüler / Dimensions (mm)							
		S	Ps	Ss	H1	H2	B1	B2	Gh
AKSOUK-200	00	28,3	28,3	40	190,0	95,0	60	180,0	100
AKSOUK-200	05	28,4	30,8	40	201,2	81,1	60	176,9	130
AKSOUK-200	10	33,3	28,7	40	190,0	120,2	60	180,0	100
AKSOUK-200	15	33,9	31,7	40	198,5	105,6	60	194,4	130
AKSOUK-200	20	30,9	24,1	32	170,0	130,0	50	190,0	100
AKSOUK-200	25	32,0	27,0	32	177,4	113,0	50	203,3	130
AKSOUK-200	30	33,5	24,5	30	170,0	150,0	30	210,0	120
AKSOUK-200	35	35,4	28,1	30	170,3	140,0	30	222,3	140
AKSOUK-200	40	39,0	27,7	30	165,0	160,0	30	210,0	120
AKSOUK-200	45	42,3	32,5	30	165,3	155,0	30	217,4	140
AKSOUK-200	50	46,7	35,8	30	160,0	160,0	10	230,0	140
AKSOUK-200	55	52,3	42,8	30	135,0	170,0	0	240,0	140
AKSOUK-200	60	60,0	52,0	30	135,0	170,0	0	240,0	140
AKSOUK-200	65	47,3	42,9	20	135,0	180,0	0	240,0	140
AKSOUK-200	70	58,5	54,9	20	135,0	180,0	0	240,0	140

 Kod / Code	(G)	(A)	Opsiyon / Option
AKSOUK	200	60	P - GY - F16